

UT15WE

3,300 lbs.

Technical Specifications



Utility you can trust[™]

Truck Dimensions

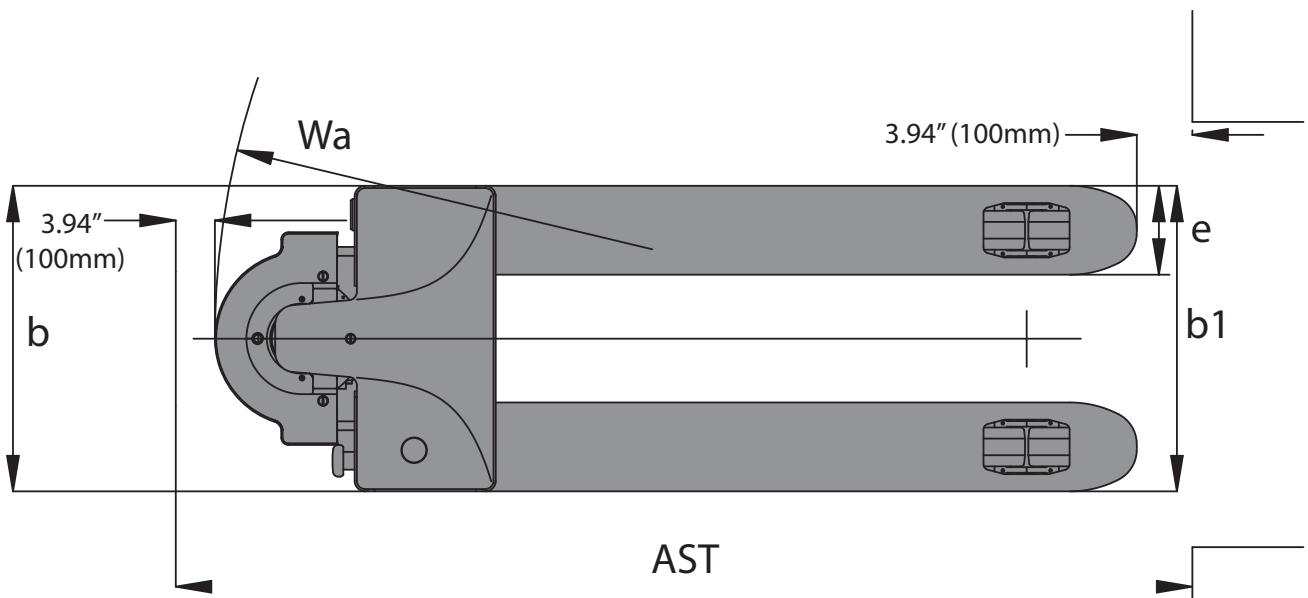
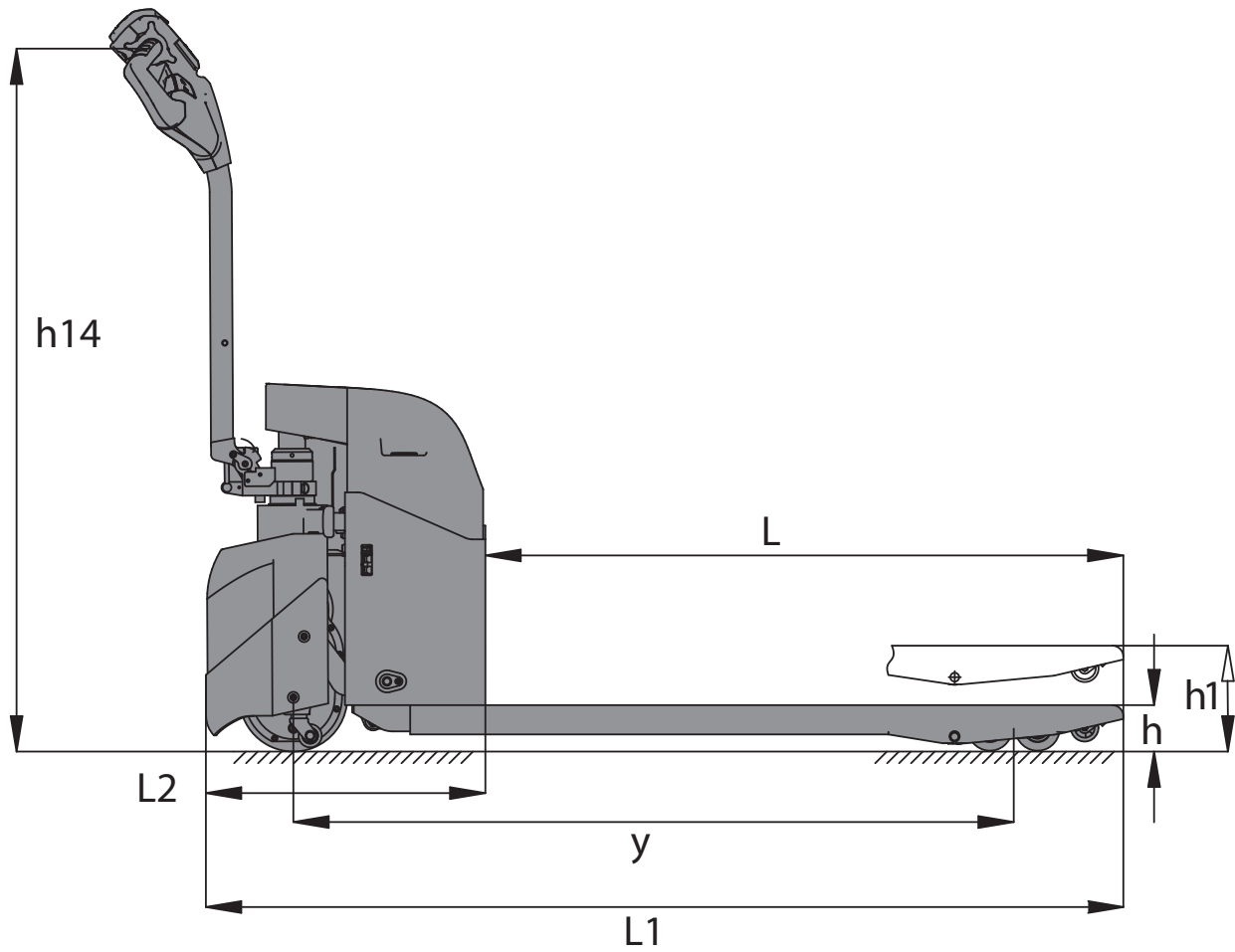

UT15WE Specifications

Characteristics	Manufacturer			UTILEV	
	Model Designation			UT15WE	
	Power Type			24-volt	
	Operator Type			Pedestrian	
	Rated Capacity		lb (kg)	3300 (1500)	
	Load Center		in (mm)	24 (600)	
	Fork Length	L	in (mm)	45.3 (1150)	
	Fork Overall Width	b1	in (mm)	27 (685) 20.5 (520)	
	Fork Width (Individual Fork)	e	in (mm)	6.3 (160)	
	Wheelbase (Raised)	y	in (mm)	50.7 (1287)	
	Wheelbase (Lowered)		in (mm)	53.4 (1357)	
Dimensions	Overall Length (Raised)	L1	in (mm)	65.1 (1654)	
	Overall Length (Lowered)		in (mm)	67.9 (1724)	
	Outside Turning Radius (Raised)	Wa	in (mm)	57.2 (1454)	
	Right Angle Stack (Raised)	AST	in (mm)	73.0 (1854)	
	Overall Lift Height – Top of Forks	h1	in (mm)	7.5 (190)	
	Lowered Height – Top of Forks	h	in (mm)	2.9 (75)	
	Total Lift		in (mm)	4.5 (115)	
	Truck Overall Width	b	in (mm)	27 (685) 20.5 (520)	
	Chassis Length	L2	in (mm)	19.8 (504)	
	Height of Tiller (max.)	h14	in (mm)	50.0 (1270)	
	Battery Compartment – Standard		in (mm)	9 / 5.4 / 8.4 (228 / 138 / 214)	
	Other	Maximum Gradeability (Loaded / Unloaded)		%	5% / 10%
		Maximum Travel Speed (Loaded / Unloaded)		mph (kph)	2.7 / 3.0 (4.3 / 4.8)
Traction Motor Control Method Type				DC	
Service Brake Type				Electric	
Truck Weight (approximate) with battery - NL/RL			lb (kg)	451.9 (205) / 3752 (1705)	
Drive Tire – Size/Type (Number of Wheels)			in (mm)	7.7 (195) Poly	
Load Wheel – Size/Type (Number of Wheels)			in (mm)	2.9 x 3.7 (74 x 93) Single	
Battery Type				GEL	
Battery Ampere Hours			Ah	65	
Battery Weight			lb (kg)	79.4 (36)	

UT15WE Features

	Package 1	Package 2	Package 3	Package 4	Package 5
3,300 lbs. capacity	✓	✓	✓	✓	✓
110 volt on-board charger	✓	✓	✓	✓	✓
24-volt	✓	✓	✓	✓	✓
(2) 12V AGM deep-cycle batteries, 65 amp hrs.	✓	✓	✓	✓	✓
7.7" (195 mm) poly drive tire	✓	✓	✓	✓	✓
2.9" X 3.7" (74 X 93 mm) single load wheel	✓	✓	✓	✓	✓
27" X 45" (685 X 1150 mm) forks	✓	✓	✓		
20.5" X 45" (520 X 1150 mm) forks				✓	✓
48" (1220 mm) load backrest		✓			✓
60" (1524 mm) load backrest			✓		
12 month / 1,000 hr. Parts & Labor Warranty	✓	✓	✓	✓	✓

Utility you can trust™

The UTILEV® range of affordable forklift trucks delivers reliable and cost-effective materials handling solutions for applications across many industries, particularly where users require equipment without advanced functionality.

The product range has been designed to be easy to operate and maintain, and is backed up by a standard warranty and comprehensive parts availability.

Furthermore, a network of experienced resellers is on hand to provide maintenance and support.

Easy to Maintain

Thanks to the simplicity of the components and specification, servicing can be carried out quickly and easily, even when PCs, laptops or diagnostic tools are not available.

Simple to Use

The ergonomically designed control handle minimizes wrist movement and provides a solid grip for additional control while operating the unit. Lift, lower, and horn buttons are conveniently located at the operator's fingertips. The butterfly throttle control provides multiple grip positions, minimizing operator fatigue while allowing travel direction and speed to be selected by rotating the actuator in the desired direction of travel.

A range of standard features help to ensure that the truck is configured to the needs of the application.

Affordable to Own

The use of proven, high quality and robust components result in reliable operation and lower wear and tear. This - together with the fast availability of cost-effective replacement parts - helps to reduce service and maintenance requirements and costs.

